



Genesee

BIOMEDICAL, INC.

Design beyond standard.

Instructions for Use

**TransForm™ McCarthy
Mitral Annuloplasty Ring
Model TF-XX**

*CAUTION: Federal law (USA) restricts this device to sale by,
or on the order of, a physician*

1. Device Description

The TransForm™ McCarthy Mitral Annuloplasty Ring is an implantable, semi-rigid annuloplasty ring for mitral valve repair with the stiffened portions at the anterior and posterior segments. The ring is flexible at the commissure regions to allow physiological movement of the annulus. Stiffener placement allows the ring to maintain its saddle shape during systole and a flat planar “O” shape in diastole. The stiffeners consist of MP35N 0.71 mm diameter (polished and formed) alloy. An elastic silicone core and braided polyester fabric form the ring body. The TransForm Annuloplasty Ring has four green radial markers: two markers at the left and right trigones and two markers at the mid-anterior and mid-posterior. The ring conforms to the natural mitral annulus throughout the cardiac cycle. The interrupted stiffeners within the silicone core provide semi-rigid elastic flexibility. The size range of TransForm is from 24mm to 40mm with 2mm increments. Size refers to the internal CC diameter of the ring. Rings are intended to be implanted on the patient’s mitral annulus to reduce and stabilize the annulus. The internal stiffeners and the radiopaque silicone provide radiographic visualization along the entire length of the ring. The braided polyester fabric serves as the sewing cuff for suture placement. The stiffeners are designed to conform to the non-planar annulus.

Ring Size	CC Diameter (mm)	AP Diameter (mm)
24 x 18	24	18
26 x 19	26	19
28 x 21	28	21
30 x 22	30	22
32 x 24	32	24
34 x 25	34	25
36 x 27	36	27
38 x 28	38	28
40 x 30	40	30

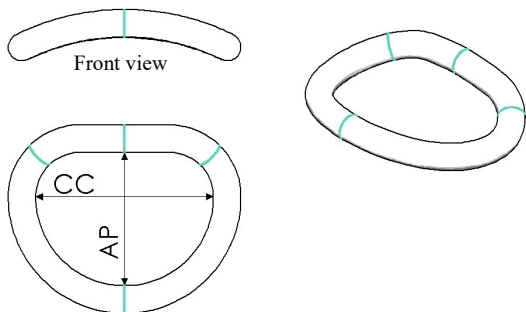

Figure 1 TransForm McCarthy Mitral Annuloplasty Ring Principal Dimensions

2. Indications for Use

TransForm McCarthy Mitral Annuloplasty Ring is indicated for use in patients undergoing surgery for diseased or damaged mitral valves. The ring provides support for and restricts expansion of the mitral annulus.

3. Contraindications

- Severe, generalized or localized bacterial endocarditis
- Heavily calcified valves
- Greatly dilated annulus (not reducible by standard techniques)
- Severe valvular dysfunction (not correctable by standard techniques)
- Valvular retraction with severely reduced mobility
- Congenital malformations with lack of valvular tissue

4. Warnings

Only surgeons who have received adequate training to determine whether incompetent, stenotic, or diseased heart valves are capable of being repaired or replaced should use this device.

Only surgeons that have received appropriate training in valve repair, including ring implant and sizing techniques, should use this device.

Correct annuloplasty ring sizing is an important element of a successful valve repair. Undersizing the ring can result in valve stenosis, systolic anterior motion of the anterior leaflet of the mitral valve, and/or ring dehiscence. Oversizing the ring can result in valve regurgitation and/or ring dehiscence.

Sutures should not be placed in the coronary sinus, coronary artery, AV node, bundle of His or other conduction tissue, as this may result in impairment of the cardiac conduction system.

Suture knots must be securely tied. Loose knots and long suture tails may be a source for hemolysis, thrombosis, or thromboembolism.

The ring should not be cut, as resultant loose threads can be a source of hemolysis, thrombosis, and/or thromboembolism.

Intraoperative and/or postoperative echocardiography assessment should be used to evaluate the effectiveness of the valve repair. Minimizing regurgitation is an important element of an effective repair.

Surgeons who use annuloplasty rings should be current on all anticoagulation regimens. When postoperative anticoagulant therapy is used, the patient's anticoagulation status should be carefully monitored.

The surgeon may determine that patients in atrial fibrillation remain on anticoagulation therapy until sinus rhythm is established.

5. Precautions

Do not use cutting edge needles, as they may damage the annuloplasty ring, potentially leading to dehiscence and possible regurgitation.

Take care not to damage the annuloplasty ring during handling.

This device is for single patient use only.

Do not re-use, reprocess, or re-sterilize this product.

Re-use, reprocessing, or re-sterilization may compromise the structural integrity of the device and/or create a risk of contamination of the device, which could result in patient injury, illness, or death.

6. Potential Adverse Events

While infrequent, certain complications have been reported when using an annuloplasty ring. These include the following:

- uncorrected or recurrent regurgitation
- left ventricular outflow tract obstruction
- systolic anterior motion
- stenosis
- ring fracture
- dehiscence
- hemolysis (even with mild regurgitation)
- low cardiac output
- cardiac arrhythmia
- heart block
- damage to coronary arteries
- endocarditis
- thrombosis
- thromboembolism
- anticoagulant-related hemorrhage
- leaflet perforation

The potential for these complications should be considered when selecting the most beneficial surgical procedure for each patient. To avoid or minimize occurrence of these adverse events, the annuloplasty repair, including sizing and implantation, should be conducted in accordance with the

methods described in these Instructions for Use by surgeons with appropriate training and experience in valve repair.

7. Individualization of Treatment

To allow for healing and incorporation of the annuloplasty ring by host tissue, regardless of cardiac rhythm, postoperative anticoagulation therapy should be considered for at least six weeks following surgery.

8. Patient Counseling Information

Patient dental care: Patients with annuloplasty ring who undergo dental or other potentially bacteremic procedures must be considered for prophylactic antibiotic therapy.

9. MRI Safety Information, 1.5-Tesla and 3-Tesla



MR Conditional

Non-clinical testing has demonstrated that the TransForm McCarthy Mitral Annuloplasty Ring is MR Conditional.

A patient with the TransForm McCarthy Mitral Annuloplasty Ring can be safely scanned in an MR system under the following conditions:

- Static magnetic field of 1.5-Tesla and 3-Tesla, only
- Maximum spatial gradient magnetic field of 5,000-Gauss/cm (50-T/m)
- Maximum MR system reported, whole body averaged specific absorption rate (SAR) of 2-W/kg for 15 minutes of scanning (i.e., per pulse sequence) in the Normal Operating Mode

Under the scan conditions defined, the TransForm McCarthy Mitral Annuloplasty Ring is expected to produce a maximum temperature rise of 2°C after 15-minutes of continuous scanning (i.e., per pulse sequence).

In non-clinical testing, the image artifact caused by the TransForm McCarthy Mitral Annuloplasty Ring extends approximately 10-mm from this implant when imaged using a gradient echo pulse sequence and a 3-Tesla MR system.

10. MRI Safety Information, 7-Tesla



MR Conditional

Non-clinical testing has demonstrated that the TransForm McCarthy Mitral Annuloplasty Ring is MR Conditional.

A patient with the TransForm McCarthy Mitral Annuloplasty Ring can be safely scanned in an MR

system under the following conditions:

- Static magnetic field of 7-Tesla, only
- Maximum spatial gradient magnetic field of 5,000-Gauss/cm (50-T/m)

Important Note: The TransForm McCarthy Mitral Annuloplasty Ring must remain outside of all transmit or transmit/receive RF coils during MRI.

11. Packaging

TransForm is provided sterile for one time use only. The Annuloplasty Rings are sterilized using gamma radiation and are supplied in double-aseptic transfer pouches contained in an outer carton. The packaging system is designed to ease placement of the device into the sterile field. The device is sterile if the pouches are undamaged and unopened. The outer surfaces of the outer pouch are NONSTERILE and must not be placed in the sterile field.

12. Storage

Store the product in the original packaging, including the outer shelf carton, in a clean, cool, and dry area to protect the product and minimize the potential for contamination.

The sterility and non-pyrogenicity of the TransForm are validated to remain unaffected until the Use-By date identified on the shelf carton, provided the pouches are not opened or damaged.

Caution: Do not re-sterilize the Annuloplasty Ring.

13. Annuloplasty Accessories

The accessories consist of sizers and handles. Sizers are used for selecting the correct size ring for the individual patient. The handle and stainless-steel sizers have malleable stems. The sizers and handles are supplied non-sterile and must be cleaned and steam sterilized before the first use and all subsequent uses.

Information regarding the accessories may be found in the Genesee BioMedical Annuloplasty Accessories Instructions for Use. (Provided with accessories)

Handles and sizers are provided NONSTERILE — they must be cleaned and sterilized prior to each use. Do not use other manufacturers' annuloplasty sizers or handles from other annuloplasty products.

The handles are designed to engage and lock in position with the existing Genesee BioMedical silicone sizers as well as with all Genesee BioMedical Annuloplasty Rings with holders.

To attach the handle to a silicone sizer, orient the sizer with the opening in the center and insert the handle until it slips into place. The sizer's outer edge and parallel slots match the outer and inner profiles of the implanted TransForm Ring. The radial slots along represent the trigone, mid-anterior, and mid-

posterior markers. Sizing for commissure-commissure (CC) and anteroposterior (AP) are designated on each sizer. Blue arrows indicate significant features in Figure 2.

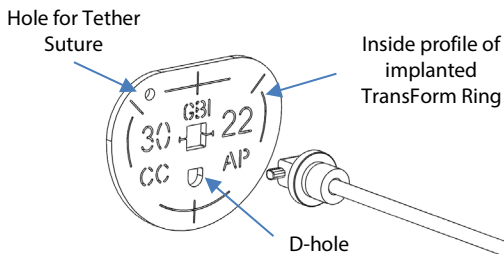

Figure 2: Flexible TFRS Sizer and GRH Handle

The flexible silicone sizers have a small hole at the upper left that may be used for placement of a tether suture. Use of a tether suture may be helpful as this may aid sizer removal when sizing is completed. This is most useful in minimally invasive and robotic procedures.

The flexible silicone sizers are designed to be adaptable for port-access and minimally invasive approaches and can be folded for easier insertion and placement. The flexible sizers can be held and manipulated by surgical instruments using the center square hole (T-slot) and the offset D-hole in the sizer.

The stainless-steel sizer is a double-ended handle with sizers at each end. The sizer stems are malleable and may be adjusted for visualization during use. The profile of the sizer is identical to the profile of an implanted TransForm Annuloplasty Ring, with the markings representing the trigone and mid-anterior locations.

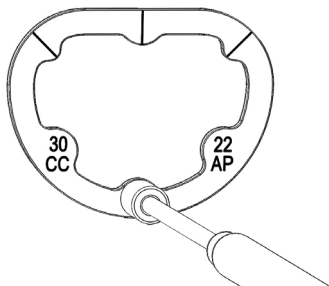

Figure 3: Stainless-Steel TFSS TransForm Sizer

Precaution: Do not use other manufacturers' annuloplasty sizers, or handles from other annuloplasty products, to size the Annuloplasty Ring. Other sizers may not indicate the appropriate ring size as they reflect the size of other rings.

The Annuloplasty Scale (Model GSC) features 1mm tick marks along either side of a straight edge, providing a minimalistic profile to take length measurements during annuloplasty (Figure 4).

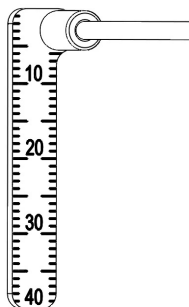

Figure 4: Annuloplasty Scale, GSC

See §16 Mitral Ring Sizing for using the different sizers and scale.

14. Device Handling

Inspect the pouches containing the device, ensure they have not been opened or damaged. The device is sterile as long as the inner pouch has not been compromised. If the inner pouch is damaged, do not implant the device. If the outer pouch is damaged, the exterior surface of the inner pouch may not be sterile.

Open the outer transfer pouch and, while still holding the bottom of the outer pouch, pass the inner pouch into the sterile field. The inner pouch should be opened only in the sterile field.

15. Device Preparation

Remove the appropriately sized ring from the sterile package using aseptic technique. The Annuloplasty Ring may be used with or without the handle (Model GRH, GRH-U, GRH-XL, or GRH-UXL).

Remove the serial number identification tag by cutting the retaining suture. Dispose of the retaining suture.

Record the serial number printed on the identification tag in the patient's record. Verify that the serial number matches the serial number on the package.

Warning: The serial number identification tag must be removed from the ring for proper function. Do not cut or tear the ring fabric during removal of the serial number identification tag.

16. Mitral Ring Sizing

Sizers are provided to determine the proper size ring. There are two sizing options to determine ring size. Historically, the sizer can be held against the anterior leaflet to judge the size of the ring based on

the dimensions of the anterior leaflet, annulus, and commissure-to-commissure dimensions, and/or surface area of the anterior leaflet.

Alternatively, use the scale to measure the mid-anterior leaflet (A2) length and mid-posterior leaflet length, then select the TransForm Ring which will provide a coaptation length that will restore valve competence, but not so small that it will cause systolic anterior motion.

Published algorithm¹:

$$\text{Coaptation Length} = \frac{A2 + P2 - \text{Ring AP}}{2}$$

These measurements can be acquired using the scale from the base of the mid-anterior leaflet to the free edge of the leaflet (A2). The posterior leaflet measurement is made after leaflet reconstruction, from the base of the mid-posterior leaflet to the free edge. For posterior leaflet repair techniques involving neochord without resection, use the scale to estimate the length from the base of the posterior leaflet to the estimated point of coaptation. The A2 length closely approximates the TransForm AP ring diameter to provide a successful repair and leaflet coaptation length.

Do not use annuloplasty ring sizers from other annuloplasty products or manufacturers to select the TransForm Annuloplasty Ring size as they reflect the size of other rings.

17. Techniques for Suture Placement and Ring Implantation

Implantation can be completed using current and established surgical techniques. The following is one possible method of suturing the ring: Place interrupted sutures, approximately 4 mm apart, continuously along the entire annulus. Markers are provided on the sewing cuff to aid in suture placement and to correctly orient the ring relative to the commissures.

Warning: Do not place sutures in the coronary sinus, coronary artery, AV node, bundle of His, or other conduction tissue. Note: Pledgets may be used with annular sutures to reduce the possibility of ring dehiscence.

18. Use of Accessories, Handles and Holder

Handles and sizers are provided NONSTERILE; they must be cleaned and sterilized prior to each use.

The handle is designed to engage and lock in position with the TransForm Annuloplasty Ring

holder. The handle is used with the holder to position the ring for suture placement.

To attach the handle to the holder, locate and orient the square recess in the holder. Insert the handle head into the square recess in the holder. If using GRH, line up the prongs with the slots and fully insert (Figure 5); if using GRH-U, insert until the plastic clip engages with the backside of the holder.

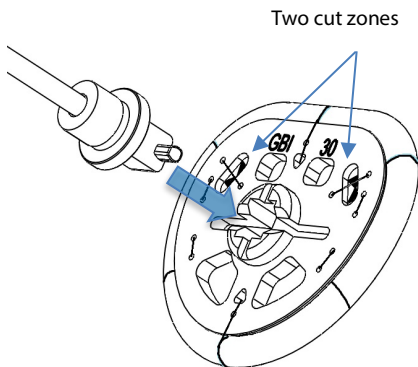

Figure 5: Inserting GRH Handle into Holder

The metal shaft of the handle is made of malleable nitinol that will straighten during the recommended steam sterilization cycle.

Take care to place the handle on the front side of the holder with the holder facing up. To remove the handle, gently pull off the handle while the holder is secured.

Precaution: Do not use annuloplasty accessories from other annuloplasty products or manufacturers to implant the TransForm Annuloplasty Ring

The handle can be used to slide the ring down onto the valve annulus while gently placing tension on the sutures. If required, bend the handle stem by grasping the handle with one hand and applying pressure to the handle stem between the thumb and forefinger of the other hand. Do not grasp the annuloplasty holder when bending the handle stem.

The handle is attached to the holder by pressing the handle into the turret on the holder (Figure 5).

The handle is removed from holder by gripping the holder at the connection point while pulling the handle off. The handle is reusable (see Section 22 on Re-sterilization).

19. Holder Removal

The holder is removed from the ring by cutting two stitches located in the cut zones. Locations of the cut zones are indicated by arrows (Figure 5). Use of No. 11 or 15 scalpel blade is recommended for cutting

the stay-suture. Cutting the suture in both cut zones is required. Do not cut any other black sutures. Do not cut the ring/ring fabric while cutting the holder retention sutures.

It is recommended that the holder and handle be removed during the implantation procedure just prior to tying the sutures. After the holder is detached from the annuloplasty ring, the handle is disconnected from the holder by gripping the holder at the connection point while pulling the handle off.

The handle is reusable. (See Instructions for Use of Genesee BioMedical Annuloplasty Accessories). Remove the holder from the ring using atraumatic forceps if necessary. If required, disengage the handle from the holder by gently pressing against the surface of the holder when pulling the handle away from the holder. After the holder is detached from the ring, discard the holder.

Tie the sutures around the ring securely and trim all excess sutures.

Warning: Under no circumstances is the holder to remain attached to the annuloplasty ring after implantation.

Uncorrected or recurrent regurgitation is a potential complication associated with annuloplasty ring.

The annuloplasty ring should be tested for competence by filling the left ventricle and observing leaflet coaptation.

20. Use of Anticoagulants

Thrombosis and thromboembolism are potential complications associated with annuloplasty rings. There is a possible need for postoperative anticoagulant therapy, surgeons should consider anticoagulation regimens for patients with annuloplasty rings. Anticoagulation therapy should be considered post-implantation and for those patients with atrial fibrillation.

21. TransForm Annuloplasty Ring Product Designations

Annuloplasty Rings with Holder:

Model #	Description
TF-24	TransForm McCarthy Mitral Annuloplasty Ring, size 24CC x 18AP
TF-26	TransForm McCarthy Mitral Annuloplasty Ring, size 26CC x 19AP
TF-28	TransForm McCarthy Mitral Annuloplasty Ring, size 28CC x 21AP
TF-30	TransForm McCarthy Mitral Annuloplasty Ring, size 30CC x 22AP
TF-32	TransForm McCarthy Mitral Annuloplasty Ring, size 32CC x 24AP
TF-34	TransForm McCarthy Mitral Annuloplasty Ring, size 34CC x 25AP
TF-36	TransForm McCarthy Mitral Annuloplasty Ring, size 36CC x 27AP
TF-38	TransForm McCarthy Mitral Annuloplasty Ring, size 38CC x 28AP
TF-40	TransForm McCarthy Mitral Annuloplasty Ring, size 40CC x 30AP

22. Cleaning and Sterilization for Accessories

The following accessories are compatible with the TransForm Annuloplasty Ring

Accessory	Model #	Description
TransForm Stainless-Steel Sizers	TFSS	Set of 4 stainless-steel double-ended sizers (26/28, 30/32, 34/36, 38/40). Includes Sterilization Tray, 1 GRH handle and 1 GRH-U handle
TransForm Flexible Silicone Sizer	TFRS	Set of 8 flexible silicone sizers (26, 28, 30, 32, 34, 36, 38, 40)
Annuloplasty Scale	GSC	Annuloplasty Scale with malleable nitinol stem
Handle	GRH	GBI Reusable Handle with malleable stem
Handle	GRH-U	Universal GBI Reusable Handle with malleable stem
Handle XL	GRH-XL	GBI Reusable Handle with malleable stem; extra-long
Handle XL	GRH-UXL	Universal GBI Reusable Handle with malleable stem; extra-long

Validated Procedure for cleaning and sterilization of the accessories is provided on the following pages.

Manual Cleaning Procedure

Step	Process	Minimum Water Quality / Temperature	Cleaning Instructions
1	Rinse	Utility Water 20-35° C	Remove contaminants using running water for 1 min. Use a soft-bristle brush (for example, a nylon toothbrush) to clean the devices thoroughly.
2	Soak	Utility Water 20-55° C	Submerge the devices completely for a minimum of 5 min with enzymatic detergent and water, mixed according to manufacturer's directions. Remove visible contaminants with a soft-bristled brush.
3	Ultrasonic Clean	Utility Water 20-55° C	Submerge the devices completely in an ultrasonic cleaner with enzymatic detergent and water, mixed according to manufacturer's directions. Sonicate for a minimum of 10 min.
4	Rinse	Critical Water 25-50° C	Rinse the devices with running water for 1 min.
5	Dry	N/A	Dry with a clean, lint-free wipe.
6	Inspect	N/A	Visually inspect each device for any remaining contaminants or moisture. If any contaminants remain, repeat the process.

Steam Sterilization Cycle Parameters

Cycle Type	Pre-Vacuum	Pre-Vacuum
Temperature	132°C (270°F)	135°C (275°F)
Exposure	4 minutes	3 minutes
Drying Time	20 minutes	16 minutes

Cycle Type	Pre-Vacuum for CJD
Temperature	134°C (273°F)
Exposure	18 minutes
Drying Time	30 minutes

For more information regarding accessories refer to the Genesee BioMedical Annuloplasty Accessories Instructions for Use.

23. References

1. McCarthy, P. M., Herborn, J., Kruse, J., Liu, M., Andrei, A.-C., & Thomas, J. D. (2022). A multiparameter algorithm to guide repair of degenerative mitral regurgitation. *The Journal of Thoracic and Cardiovascular Surgery*, 164(3):867-876.e5.
<https://doi.org/10.1016/j.jtcvs.2020.09.129>

CAUTION: Federal law (USA) restricts this device to sale by, or on the order of, a physician.

THE FOLLOWING DISCLAIMER OF WARRANTY APPLIES TO UNITED STATES CUSTOMERS ONLY:

ALTHOUGH THE TRANSFORM MCCARTHY MITRAL ANNULOPLASTY RING AND ACCESSORIES, HEREAFTER REFERRED TO AS "PRODUCT", HAVE BEEN DESIGNED, MANUFACTURED AND TESTED UNDER CAREFULLY CONTROLLED CONDITIONS, DUE TO CONDITIONS AND FACTORS THAT ARE OUTSIDE OF GENESEE BIOMEDICAL'S SUPERVISION AND CONTROL AFTER SALE OF THE PRODUCT, GENESEE BIOMEDICAL HEREBY DISCLAIMS ALL WARRANTIES EXPRESSED OR IMPLIED WITH RESPECT TO THE PRODUCT, INCLUDING BUT NOT LIMITED TO ANY IMPLIED WARRANTY OF MERCHANTABILITY OR FITNESS FOR A PARTICULAR PURPOSE. GENESEE BIOMEDICAL, INC. SHALL NOT BE LIABLE TO ANY PERSON OR ENTITY FOR ANY DIRECT, INDIRECT, INCIDENTAL, CONSEQUENTIAL, SPECIAL OR OTHER TYPE OF DAMAGES INCLUDING, WITHOUT LIMITATION, ANY MEDICAL EXPENSES CAUSED BY OR RELATED TO ANY USE, DEFECT, FAILURE OR MALFUNCTION OF THE PRODUCT, WHETHER BASED UPON A WARRANTY, CONTRACT, TORT OR OTHER LEGAL THEORY. GENESEE BIOMEDICAL, INC. NEITHER ASSUMES, NOR AUTHORIZES ANY OTHER PARTY TO ASSUME FOR IT, ANY WARRANTY, REPRESENTATION OR OTHER LIABILITY IN CONNECTION WITH THE PRODUCT OR ITS USE.

THE FOLLOWING DISCLAIMER OF WARRANTY APPLIES TO CUSTOMERS OUTSIDE THE UNITED STATES:

DISCLAIMER OF WARRANTY:

ALTHOUGH THE TRANSFORM MCCARTHY MITRAL ANNULOPLASTY RING, AND ACCESSORIES, HEREAFTER REFERRED TO AS "PRODUCT" HAVE BEEN CAREFULLY DESIGNED, MANUFACTURED AND TESTED PRIOR TO SALE, THE PRODUCT MAY FAIL TO PERFORM ITS INTENDED FUNCTION SATISFACTORILY FOR A VARIETY OF REASONS. THE WARNINGS CONTAINED IN THE PRODUCT LABELING PROVIDE MORE DETAILED INFORMATION AND ARE CONSIDERED AN INTEGRAL PART OF THIS DISCLAIMER OF WARRANTY. GENESEE BIOMEDICAL, INC., THEREFORE, DISCLAIMS ALL WARRANTIES, BOTH EXPRESS AND IMPLIED, WITH RESPECT TO THE PRODUCT. GENESEE BIOMEDICAL, INC. SHALL NOT BE LIABLE FOR ANY INCIDENTAL OR CONSEQUENTIAL DAMAGES CAUSED BY ANY USE, DEFECT OR FAILURE OF THE PRODUCT, WHETHER THE CLAIM IS BASED ON WARRANTY, CONTRACT, TORT OR OTHERWISE.

If any term or portion of this Disclaimer of Warranty and Liability provision is found to be unenforceable, illegal or contrary to applicable law by a court of competent jurisdiction, the remaining portions of this provision shall not be affected and shall remain valid, and any such unenforceability or illegality in jurisdiction shall not invalidate or render unenforceable this Disclaimer of Warranty and Liability provision any other jurisdiction.

Manufacturer:

Genesee BioMedical, Inc.

700 W Mississippi Ave. Unit D5

Denver, CO 80223-4509, USA

Toll Free: (800) 786-4890

Phone: (303) 777-3000

Fax: (303) 777-8866

cservice@geneseebiomedical.com

www.geneseebiomedical.com

© 2025 Genesee BioMedical, Inc.

223006R02